

DHC-2200R

Serial Number

E8074500001-E80745999999

Last updated date

21/Jul/2023

TABLE OF CONTENTS

MOTOR, GEAR CASE.....	1
CUTTING BLADE	3
HANDLE.....	5
CONTROL	7
ACCESSORIES	9

MOTOR, GEAR CASE

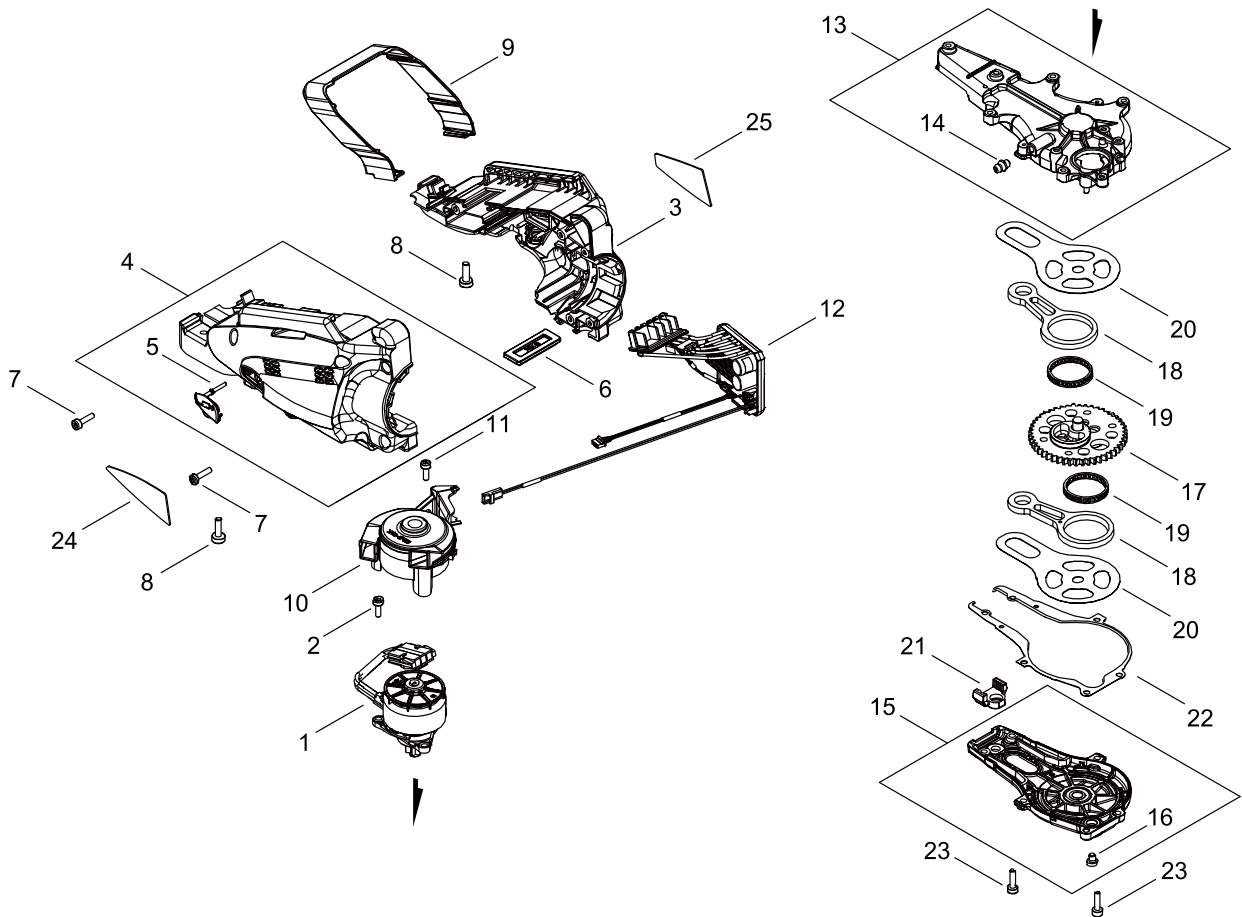

MOTOR, GEAR CASE

Key No.	LV (+)	Parts Number	Parts Description	Qty	Standard	Class
1		A054-000370	MOTOR,ASM	1		D
2		V804-000050	BOLT, TORX 4	3	TB-4*12 10.9	C
3		A539-000540	COVER,MOTOR	1		C
4		P100-013460	COVER,MOTOR ASY	1		
5	+	X638-000010	CAP,NIPPLE	1		D
6		V420-005780	CUSHION	1		B
7		V804-000170	BOLT, TORX 4	5	TT-P 4*16	C
8		V805-000150	BOLT, TORX 5	4	TB-5*16 10.9	C
9		J470-009390	COVER	1		D
10		P100-013060	CASE,FAN ASY	1		C
11		V804-000050	BOLT, TORX 4	1	TB-4*12 10.9	C
12		A047-000640	BOARD,ASM CONTROL	1		D
13		P100-013100	CASE ASY, GEAR	1		C
14	+	V187-000080	GREASE NIPPLE	1		C
15		P100-013110	LID ASY, GEARCASE	1		D
16	+	V203-002640	BOLT,5	1	TB-5*6	C
17		P100-013121	GEAR,SPUR	1		
18		C532-000700	ROD, CONNECTING	2		C
19		V572-000000	BEARING, NEEDLE	2		C
20		C603-001270	PLATE, SIDE	2		C
21		V541-000620	SEAL	1		C
22		V110-000260	GASKET,GEAR CASE	1		A
23		V804-000060	BOLT, TORX 4	5	TB-4*16 10.9	C
24		X543-006190	LABEL,MODEL	1	DHC-2200R	D
25		X502-001340	LABEL,ECHO	1		D

Class : Consumable class

A:Fast moving parts B:Semi-fast moving parts C:Slow moving parts D:Order only as needed

CUTTING BLADE

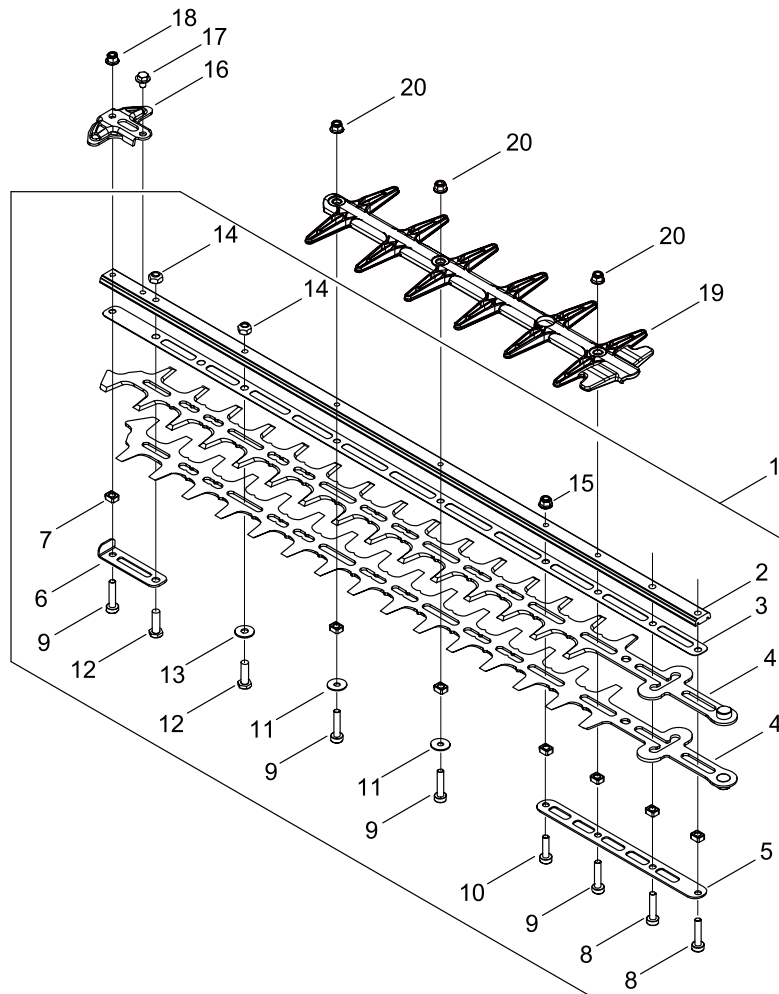

CUTTING BLADE

Key No.	LV (+)	Parts Number	Parts Description	Qty	Standard	Class
1		X041-000810	CUTTER,ASM	1		B
2	+	X425-001210	SUPPORT,CUTTER	1		B
3	+	X425-001220	SUPPORT,CUTTER	1		B
4	+	X411-001400	CUTTER	2		A
5	+	X425-001230	SUPPORT,CUTTER	1		B
6	+	X425-001240	SUPPORT,CUTTER	1		B
7	+	V376-002940	SPACER	7	7.45*9*4.7	C
8	+	V805-000220	BOLT, TORX 5	2	TB-5*25 12.9	C
9	+	V805-000170	BOLT, TORX 5	4	TB-5*25 10.9	C
10	+	V805-000160	BOLT, TORX 5	1	TB-5*20 10.9	C
11	+	V303-000290	WASHER	2		C
12	+	V204-000570	BOLT	2	M6*20	C
13	+	V304-000240	WASHER	1		C
14	+	433022-06460	NUT	2		C
15	+	92108-05000	NUT, FLANGE	1	5	
16		E278-000390	PROTECTOR	1		C
17		V203-002630	BOLT,5	1		C
18		92108-05000	NUT, FLANGE	1	5	
19		X431-000280	BLUNT	1		C
20		92108-05000	NUT, FLANGE	3	5	

Class : Consumable class

A:Fast moving parts B:Semi-fast moving parts C:Slow moving parts D:Order only as needed

HANDLE

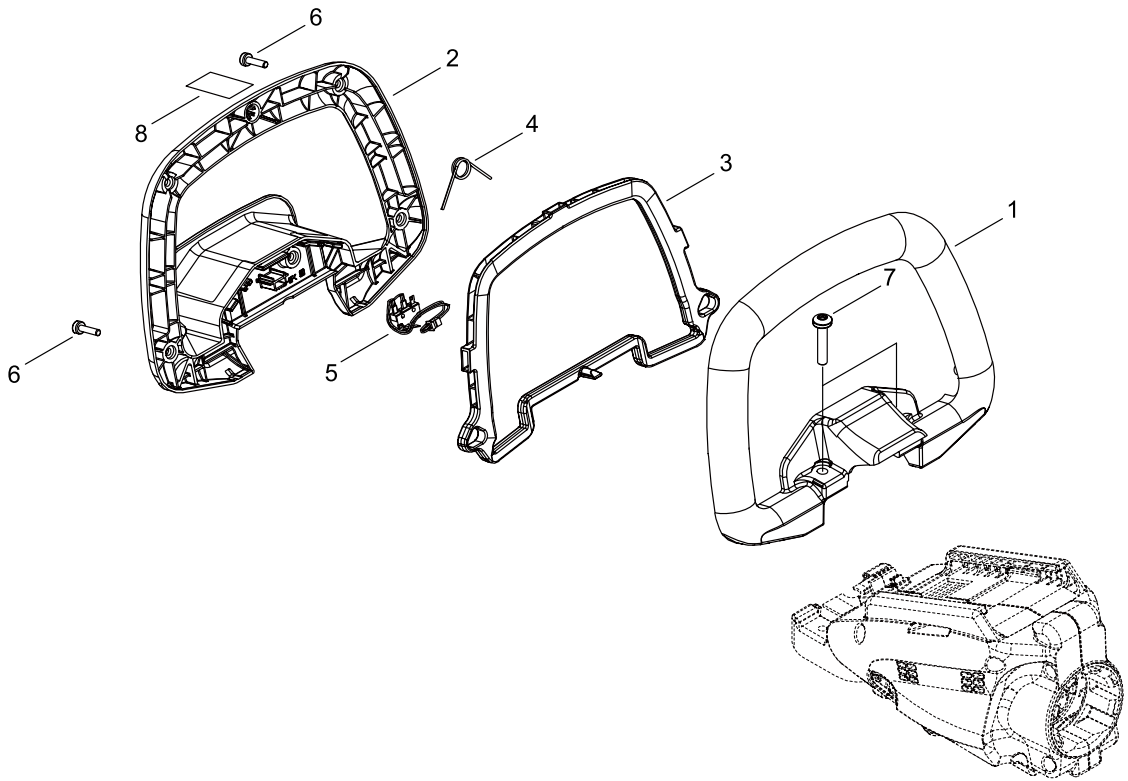

HANDLE

Key No.	LV (+)	Parts Number	Parts Description	Qty	Standard	Class
1		C400-001841	HANDLE, FRONT	1		C
2		C400-001850	HANDLE, FRONT	1		C
3		J361-000861	LEVER	1		D
4		V452-002070	SPRING,TORSION	1		B
5		C130-001270	HARNESS, WIRE	1		D
6		V804-000170	BOLT, TORX 4	5	TT-P 4*16	C
7		V806-000090	BOLT, TORX 6	2	TT-6*30 DG 10.9	C
8		X505-011880	LABEL,CAUTION	1		D

Class : Consumable class

A:Fast moving parts B:Semi-fast moving parts C:Slow moving parts D:Order only as needed

CONTROL

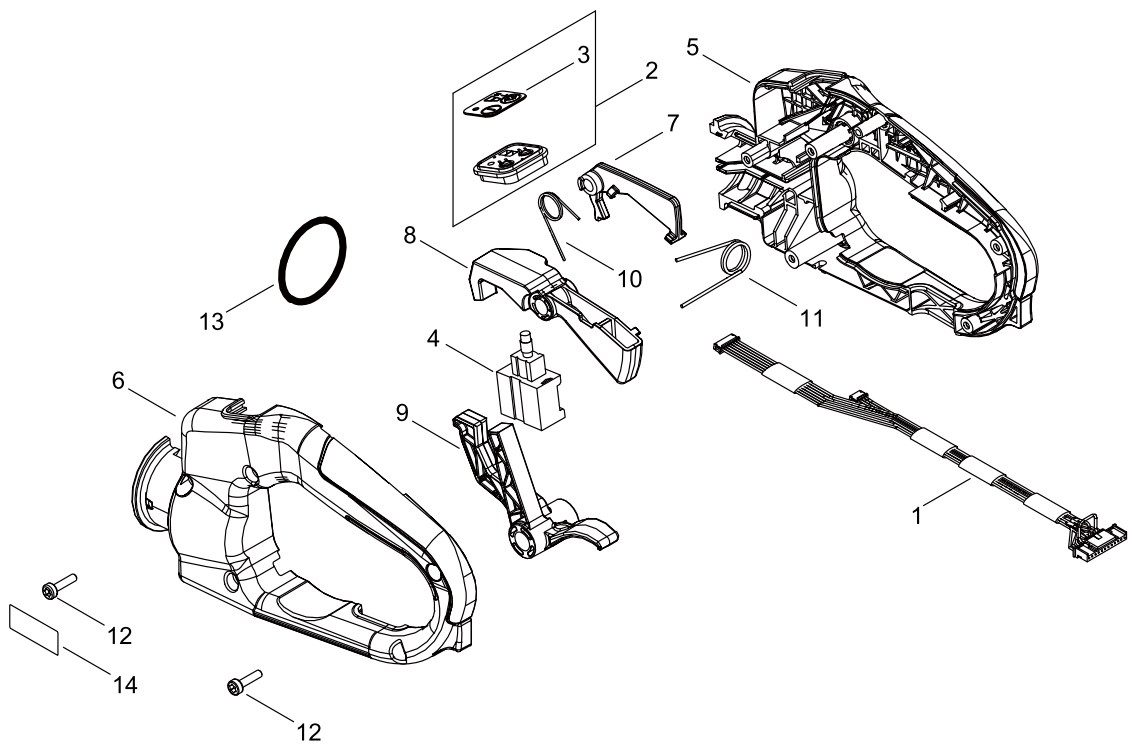

CONTROL

Key No.	LV (+)	Parts Number	Parts Description	Qty	Standard	Class
1		C130-001280	HARNES, WIRE	1		D
2		A047-000630	BOARD,ASM CONTROL	1		D
3	+	X510-001400	LABEL,SWITCH	1		D
4		G334-001830	SWITCH	1	G33407S0080	C
5		C410-001570	HANDLE, REAR	1		C
6		C410-001580	HANDLE, REAR	1		C
7		C490-000070	LOCKOUT	1		C
8		J361-000850	LEVER	1		D
9		C661-000250	LEVER, RELEASE	1		C
10		V452-002050	SPRING,TORSION	1		B
11		V452-002060	SPRING,TORSION	1		B
12		V804-000170	BOLT, TORX 4	5	TT-P 4*16	C
13		92500-04200	O-RING	1	P-42	B
14		X505-011890	LABEL,CAUTION	1		D

Class : Consumable class

A:Fast moving parts B:Semi-fast moving parts C:Slow moving parts D:Order only as needed

ACCESSORIES

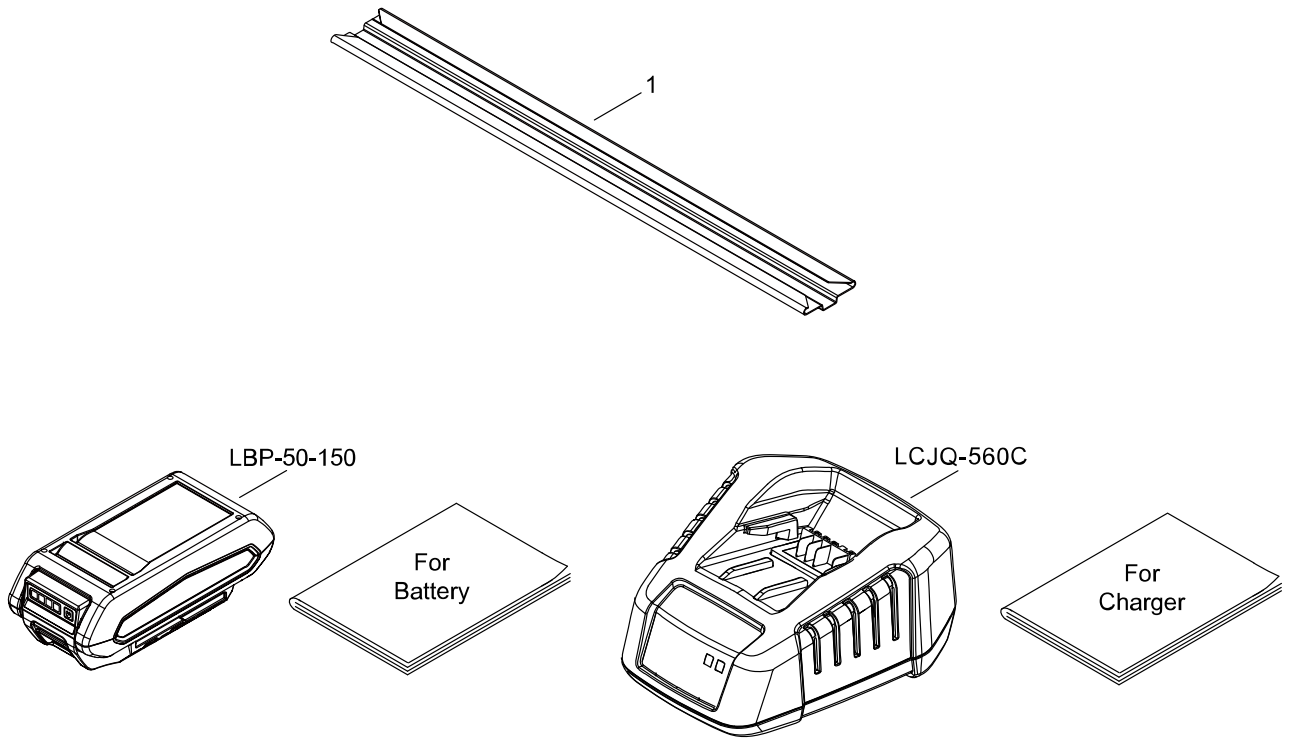

* Batteries and charger are handle as accessories instead of spare parts.
Please place an order of batteries and charger at the same time as unit order.

ACCESSORIES

Key No.	LV (+)	Parts Number	Parts Description	Qty	Standard	Class
1		X495-001080	SCABBARD,BLADE	1		D

Class : Consumable class

A:Fast moving parts B:Semi-fast moving parts C:Slow moving parts D:Order only as needed

NUMERICAL PARTS INDEX

Part No	Part description	Page	Part No	Part description	Page
433022-06460	NUT	4	V804-000170	BOLT, TORX 4	8
92108-05000	NUT, FLANGE	4	V805-000150	BOLT, TORX 5	2
92500-04200	O-RING	8	V805-000160	BOLT, TORX 5	4
A047-000630	BOARD,ASM CONTROL	8	V805-000170	BOLT, TORX 5	4
A047-000640	BOARD,ASM CONTROL	2	V805-000220	BOLT, TORX 5	4
A054-000370	MOTOR,ASM	2	V806-000090	BOLT, TORX 6	6
A539-000540	COVER,MOTOR	2	X041-000810	CUTTER,ASM	4
C130-001270	HARNESS, WIRE	6	X411-001400	CUTTER	4
C130-001280	HARNESS, WIRE	8	X425-001210	SUPPORT,CUTTER	4
C400-001841	HANDLE, FRONT	6	X425-001220	SUPPORT,CUTTER	4
C400-001850	HANDLE, FRONT	6	X425-001230	SUPPORT,CUTTER	4
C410-001570	HANDLE, REAR	8	X425-001240	SUPPORT,CUTTER	4
C410-001580	HANDLE, REAR	8	X431-000280	BLUNT	4
C490-000070	LOCKOUT	8	X495-001080	SCABBARD,BLADE	10
C532-000700	ROD, CONNECTING	2	X502-001340	LABEL,ECHO	2
C603-001270	PLATE, SIDE	2	X505-011880	LABEL,CAUTION	6
C661-000250	LEVER, RELEASE	8	X505-011890	LABEL,CAUTION	8
E278-000390	PROTECTOR	4	X510-001400	LABEL,SWITCH	8
G334-001830	SWITCH	8	X543-006190	LABEL,MODEL	2
J361-000850	LEVER	8	X638-000010	CAP,NIPPLE	2
J361-000861	LEVER	6			
J470-009390	COVER	2			
P100-013060	CASE,FAN ASY	2			
P100-013100	CASE ASY, GEAR	2			
P100-013110	LID ASY, GEARCASE	2			
P100-013121	GEAR,SPUR	2			
P100-013460	COVER,MOTOR ASY	2			
V110-000260	GASKET,GEAR CASE	2			
V187-000080	GREASE NIPPLE	2			
V203-002630	BOLT,5	4			
V203-002640	BOLT,5	2			
V204-000570	BOLT	4			
V303-000290	WASHER	4			
V304-000240	WASHER	4			
V376-002940	SPACER	4			
V420-005780	CUSHION	2			
V452-002050	SPRING,TORSION	8			
V452-002060	SPRING,TORSION	8			
V452-002070	SPRING,TORSION	6			
V541-000620	SEAL	2			
V572-000000	BEARING, NEEDLE	2			
V804-000050	BOLT, TORX 4	2			
V804-000060	BOLT, TORX 4	2			
V804-000170	BOLT, TORX 4	2			
V804-000170	BOLT, TORX 4	6			